



ADVANTAGE™

MACHINE FILM

Versatile, high performing, cast film

Advantage is a reliable, quiet, and tough film that is ideal for most machine film applications, from high-speed to older equipment.

Features & Benefits

- One-sided cling
- Quiet and easy release film
- Superior puncture resistance
- Dependable cling

Ideal for

- High speed applications and equipment
- Load types: A, B, and C
- Down-gauge potential vs commodity films

JDE #	PRODUCT CODE	GAUGE	MICRONS	WIDTH (IN)	LENGTH (FT)	POUNDS PER ROLL	ROLLS PER PALLET
1597439*	ADU12720	50	12.7	20.0	9000	36.00	40
1505252*	ADU14020	55	14.0	20.0	8000	35.20	40
1505298*	ADU14030	55	14.0	30.0	8000	52.80	20
1505248	ADU15220	60	15.2	20.0	7500	36.00	40
1505296	ADU15230	60	15.2	30.0	7500	54.00	20
1597595	ADU160197	63	16.0	19.7	5000	24.82	50
1597598	ADU165197	65	16.5	19.7	7385	37.83	40
1505244	ADU16520	65	16.5	20.0	6500	33.80	40
1505293	ADU16530	70	17.8	30.0	6500	50.70	20
1597599	ADU178197	70	17.8	19.7	6000	33.10	40
1505226	ADU1782	71	18.0	20.0	6000	33.60	40
1505287	ADU17830	75	19.0	30.0	6000	50.40	20
1597601	ADU180197	80	20.3	19.7	5000	27.97	40
1597602	ADU190197	80	20.3	19.7	6400	37.82	40
1505235	ADU19020	80	20.3	20.0	6000	36.00	40
1597603	ADU203197	90	22.9	19.7	6000	37.82	40
1505215	ADU20320	90	22.9	20.0	5500	35.20	40
1505280	ADU20330	100	25.4	30.0	5500	52.80	20
1505211	ADU22920	102	25.9	20.0	5000	36.00	40
1505276	ADU22930	105	26.7	30.0	5000	54.00	20
1597605	ADU25420	115	29.2	20.0	4500	36.00	40
1505199	ADU26720	115	29.2	20.0	4250	35.70	40
1505192	ADU29220	115	115	20.0	3500	32.20	40
1505270	ADU29230	115	115	30.0	3500	48.30	20

*Metric Item specification



Edge of pallet without ripping



Excellent for A, B, and C loads

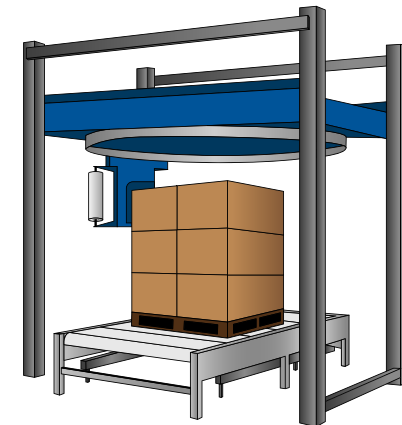

High-speed applications

Berry Global leverages our sustainability leadership, unmatched global capabilities, and deep innovation expertise to serve customers of all sizes around the world.

 **Sustainability Leadership**

Collaborating Across the Value Chain to Achieve More Together for a Circular Economy

 **Global Capabilities**

Serving Customers of All Sizes Around the World with our Unmatched Global Capabilities

 **Innovation Expertise**

Creating Innovative Packaging and Engineered Products that Make Life Better for People and the Planet

1.877.662.3779 | berryglobal.com

Our Customer Promise

We partner with customers to develop, design, and manufacture innovative products with an eye toward the circular economy. The challenges we solve and the innovations we pioneer benefit our customers at every stage of their journey.

